

Strategic Plan for the Southeast Climate Consortium Extension Program

C. Fraisse, J. Bellow, N. Breuer, V. Cabrera, J. Jones, K. Ingram, G. Hoogenboom, and Joel Paz¹

Developing climate information services and decision aids to promote the competitiveness of agriculture and to protect the natural resources of the Southeastern USA.

¹ Clyde W. Fraisse, Assistant Extension Scientist, Agricultural and Biological Engineering Department, University of Florida; John G. Bellow, Post Doctoral Research Associate, Center for Oceanic and Atmospheric Studies, Florida State University; Norman E. Breuer, Post Doctoral Research Associate, University of Miami; Victor E. Cabrera, Post Doctoral Research Associate, University of Miami; James W. Jones, Distinguished Professor, Agricultural and Biological Engineering Department, University of Florida; Keith T. Ingram, Assistant Research Scientist, Agricultural and Biological Engineering Department, University of Florida; Gerrit Hoogenboom, Professor, Department of Biological and Agricultural Engineering, University of Georgia; and Joel Paz, Public Service Assistant, Department of Biological and Agricultural Engineering, University of Georgia.

Introduction

The Southeast Climate Consortium (SECC) has its origin in the Florida Climate Consortium, which was formed in 1996 by three Florida universities (Florida State University, University of Florida, and University of Miami). Initial research of the Florida Consortium focused on the agricultural sector in Argentina, but in 1998 focus shifted to Florida. Early Florida Consortium work was supported by the National Oceanic and Atmospheric Administration as a pilot Climate Applications Project. When the Regional Integrated Sciences and Assessment (RISA) program was established, Florida Consortium work was transferred to the purview of this program. In 2002 the Florida Consortium expanded to become the SECC, initiating interactions and joint activities among consortium member institutions in Florida and Georgia and expanding the focus to the southeastern USA. USDA-RMA funding awarded in 2003 allowed the expansion of consortium activities to include Alabama with further integration of SECC activities. Current members of the SECC include Auburn University, Florida State University, University of Alabama at Huntsville, University of Florida, University of Georgia, and University of Miami. Over the past three years, the SECC has broadened its target stakeholders to not only include agricultural producers, but also water resource managers, forest managers, and policy makers.

The SECC brings together expertise from different physical, biological and social science disciplines. Our mission is to use advances in climate sciences, including improved capabilities to forecast seasonal climate, to provide scientifically sound information and decision support tools for agriculture, forestry, and water resources management in the southeastern USA.

Our approach includes partnering with outreach institutions to ensure that research is relevant for user needs and that the products of our research are provided to users via accepted and trusted mechanisms. The SECC research strengthens decision-making, knowledge application, economic security, and environmental stewardship in agriculture, forestry, and water resources in the southeastern USA.

Partnership with state Cooperative Extension Services is of paramount importance for the SECC to be successful. With that in mind, a climate Extension specialist was hired at the University of Florida during the last quarter of 2003 to liaise with agricultural Extension specialists and agents. The climate specialist job function also included the development of web-based decision aids aimed at reducing risks in agriculture associated with climate variability. Since then, a second climate extension specialist was hired by Florida State University in August of 2004 and a third specialist, just hired at the University of Georgia, will start his activities in March of 2005. The recent increase in the number of SECC members dedicated to extension activities, implementation of web-based decision aids, and consequent increase in outreach activities resulted in the need to develop a vision and a strategic plan for a SECC climate extension program.

Vision

Our vision is that agricultural, forestry and water resource managers will better cope with uncertainty and climate associated risks through routine and effective use of climate forecasts and climate related decision support tools. This vision includes a major role of Cooperative Extension Services through an outreach and an education program.

Goal

Our main goal is to develop a climate information system in the southeastern USA in which climate forecasts and information, together with decision support tools for agriculture, forestry and water resource management are made available to improve management decisions at different scales, contributing to an improved quality of life. We will develop information, decision aids, and partnerships needed by decision makers to increase profits, reduce economic risks and increase resource use efficiency. This includes provision of educational material and training programs to help stakeholders understand and use this technology effectively in their decision making process.

Overall Objectives

Our objectives are currently aimed at Florida, Georgia, and Alabama, although a long term goal is to expand to other southeastern states.

1. **Outreach:** Develop methodologies to deliver climate forecasts and customized information to agricultural, forestry and water resources managers;
2. **Research and Development:** Conduct research needed to combine and translate climate, agricultural, forestry and water resources information into decision-aid products;
3. **Partnerships:** Build relationships with extension, agricultural, forestry and water resources managers to ensure that our findings and products are relevant to stakeholders;
4. **Monitoring and Evaluation:** Document and assess the utility and impact of climate forecast information provided to stakeholders.

Approach for the SECC Extension Program

The SECC mission requires sustained interaction with various groups of stakeholders. Assessment of needs and opportunities for the use of climate information must involve agricultural producers, foresters, water resources managers as partners, to help direct our research agenda and ensure its relevance. The approach involves identification of stakeholders' needs, joint development of solutions, and implementation of delivery mechanisms to transfer climate-related risk management tools and information.

Optimization of resources and close collaboration among climate extension specialists in all states is a great advantage for the proposed system. Since climate associated problems and solutions are similar in all three states, the proposed extension system can access a larger pool of

resources and expertise to create solutions that are customized and delivered to each state at a much-reduced cost.

A major part of our effort is directed toward developing and providing climate and resource management information through *AgClimate*, the decision support system that was introduced in September of 2004 for use by Extension in management of agriculture, forests, and water resources. Although the web delivery system (www.agclimate.org) is now available to users, considerable work remains in that information is needed for many different types of agricultural systems in our three states. The success of *AgClimate* as a mechanism for disseminating climate information and decision support depends on a close and mutually beneficial relationship between SECC and Extension.

Extension Organization

The responsibility for the extension activities will be distributed among the SECC institutions based on core skills and geography. While research and development activities will be assigned based on core skills, outreach activities will be distributed based primarily on geography. Table 1 shows initial assignments of extension activities to SECC member institutions based on core skills.

Table 1. Extension Activity Assignments.

Extension Activity	AU	FSU	UF	UG	UM	UAH
Agricultural Extension	x	x	x	x		
Climate Extension		x		x		x
Social-Economic Extension	x			x	x	
Water Resource Extension			x		x	
Forestry Extension		x				

The SECC Climate Extension specialists (currently at Florida State University, University of Florida, and the University of Georgia) form the core of the SECC extension team, responsible for organizing and conducting extension outreach activities, planning and implementing development activities and supervising and executing maintenance activities. A climate extension coordinator assignment will be rotated on an annual basis among the SECC institutions. The extension coordinator will be responsible for overseeing the extension outreach activities in all states, coordinating development and maintenance activities to avoid duplication of efforts and ensure good communication among SECC members.

Advisory Committee

An extension advisory committee composed of extension faculty, county agents, producers, agribusiness, and other stakeholders will be established to help establish priorities, to guide and evaluate the development of decision aids, and to ensure the relevance of decision aids developed.

Communication protocols

As a geographically diverse team, the use of email, videoconferencing, and telephone to communicate provides a backbone to the work process of extension specialists. Sharing and preparation of publications and presentations electronically complements the use of batch email lists for the discussion of issues arising in the development, maintenance, and dissemination of climate risk management information and tools.

- *Monthly video-conferences (extension team)*: The use of the internet-based video conference link is intrinsic to the extension working plan to facilitate collaboration and productivity on a regional scale. The climate extension team will meet monthly for approximately 1 hour to discuss ongoing efforts and to plan upcoming events. Meeting dates and times will be announced in advance by email and the meetings are open to all SECC members and collaborators. A representative of the principal investigators will be encouraged to attend the meetings.
- *One-on-One meetings (extension team and County Extension Faculty)*: A lot can be learned with one-on-one informal meetings with county extension agents and producers. These informal visits and discussions are encouraged and should be an important component of the climate extension program activities.
- *Semiannual meetings (extension team and advisory committee)*: The Extension team meets on a semiannual basis in person with representatives from the advisory committees who are able to attend. The meetings rotate between institutions with an SECC extension component, currently UGA, FSU, UF, UM, and UA and take the place of the monthly video conference. Activities focus on reporting and evaluation of progress from all extension participants. New initiatives and opportunities are planned and lead individuals identified to take responsibility for their progress. The reports and planning outcomes generated during these meetings are the main reports of work progress by the extension team and are distributed to all principal investigators and made available to institutional collaborators through the coordinator's office.
- *Annual meetings (extension administration)*: Extension teams of each institution with an active extension component meet with the extension administration of their respective institutions to report on progress made during the year and plans for the next year.

Overview of Extension Activities

Extension activities undertaken by the SECC can be broadly classified under the four main objectives: 1. Outreach; 2. Research and Development; 3. Partnerships; and 4. Monitoring and Evaluation. A detailed list of extension activities currently being undertaken by all SECC institutions is given in Appendix A.

Outreach activities

Outreach includes all forms of interactions between the SECC extension team and stakeholders, from exploratory visits to identify needs to training activities and peer-reviewed publications.

- *Training Workshops* are aimed to facilitate the understanding of the fundamentals of our climate decision tools, gain confidence in their use, and identify opportunities for new climate applications. Workshops are designed for county extension agents, producers, natural resources managers, and general stakeholders with decision responsibilities over the land use. Workshops will be customized to regions and commodities in order to facilitate the discussion of climate variability impacts on situations that are of interest to participants. Training materials such as manuals and CDs will be prepared and distributed to workshop participants.
- *Participation in Traditional Extension Activities* provides the opportunity to reach a larger audience including stakeholders that are not familiar with the climate extension program. Traditional Extension Activities include commodity meetings, workshops, field days, and other types of interactions between extension faculty and growers. Our approach will be to take advantage of these programmed activities requesting a short space (20-30 minutes) to introduce the climate extension program with examples amenable and compatible with the extension activity in course.
- *In-Service Training* of extensionists is another opportunity for training that can be explored. We will work to have a climate training program endorsed by the Cooperative Extension Service (in each state) and make it available to extensionists in the three states. In-Service training courses usually last half to two days. Climate extension training would be prepared for a full day, which will include complete training programs as previously described. This will include round tables and discussions about potential impacts and implications of use of climate forecasts in agriculture, forestry and water resource management.

Research and Development

Research and development activities include the development of outreach mechanisms such as the AgClimate web site (<http://www.agclimate.org>), climate risk management “tools”, and participation in research projects together with SECC and external research scientists. In addition to development activities, there are significant maintenance activities, mainly related to the AgClimate web site, such as the updating of climate and associated forecasts and the maintenance and updating of SECC databases that need to be carried out for a successful implementation of the climate extension program.

The development of new decision aid tools for delivery through *AgClimate* is by necessity driven by diverse factors; chiefly feedback from extension scientists and producers though advances in climate forecasting or technology also permits innovation. We expect that the increase of interactions and the delivery of initial web-based tools will spark interest from all

sides to add and deliver new tools. As a limited resource system, we must ensure that new tools will be scientifically sound, relevant to a large group of stakeholders, and technically and economically feasible. Currently the SECC has a backlog of products in the research and developmental stages that will require several years for incorporation into *AgClimate*. The formal inclusion of new products into the scope of SECC activities will follow the approach outlined in Figure 1.

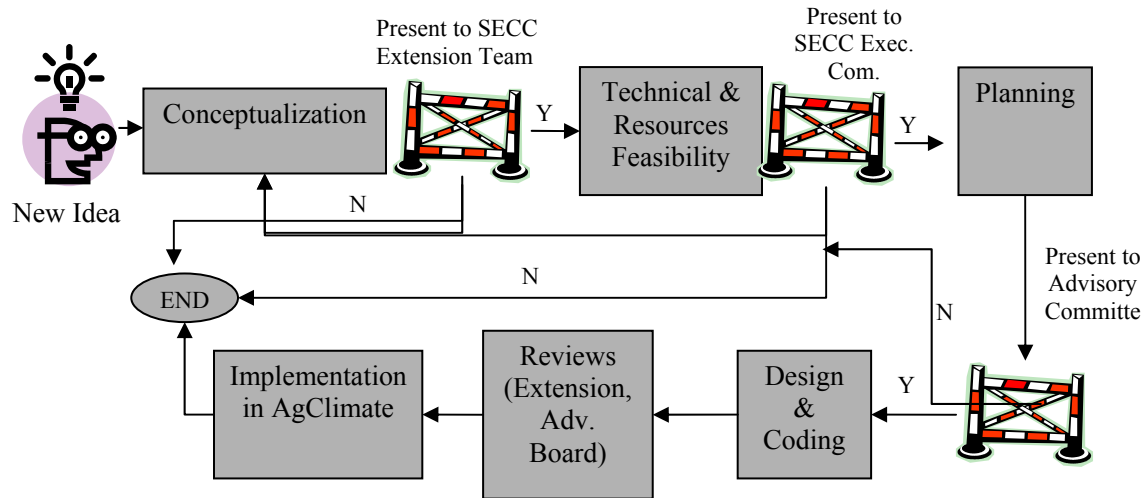

Figure 1. Schematic of the stage gate approach for development of new decision aid tools.

This approach is an adaptation of the “stage gate” approach typically used by industry to release new products. The main concept is that an idea for a new product has to overcome a number of gates through the process of its development and final implementation. Each gate is controlled by “gate keepers” that normally have the power to move the product to the next phase of implementation, to request further analysis or information before continuing its development or to stop and cancel the project. Under this proposed methodology, new activities or products will be conceptualized and presented by their authors during the monthly extension video-conferences. Once approved by the group, a more detailed technical and resources feasibility report will be prepared for presentation to SECC Executive Committee. The goal here is to assure that the science behind the new proposed extension activity or tool is sound enough to be transferred to stakeholders. Once approved by the SECC Executive Committee, a detailed plan will be developed and presented to the extension advisory committee. At this stage, approval will be based on relevance to stakeholders and funding availability. Regardless of source, new activities are discussed and planned in the context of semiannual meetings with a work plan and activity leader identified in the process. The activity leader and his/her collaborators are responsible for the development and implementation of new approved services or products. Semiannual reports of progress and status will be required for all ongoing efforts. The advisory committee approval is the last gate to be overcome before the activity development and actual implementation takes place.

When an activity reaches the stage where it could conceivably be implemented as a risk tool or regional/spatial product, the specific form and coding needs for individual tools will be identified and an interface will be developed. Implementation will include a testing phase and at

least one more review by the advisory committee and executive committee before it is formally launched. This approach ensures that resources will be spent wisely and respond to relevant needs of stakeholders.

Partnerships

As stated in our introduction, partnership with State Extension Services is very important for the SECC to be successful in achieving its main goal. Extension agents can provide:

- Access to local knowledge and experience
- Facilitate relationships with stakeholders
- Advise on format, language, and delivery systems
- Feedback and suggestions for new potential applications
- Information and technical advise to stakeholders based on SECC decision support tools

The ability of climate extension specialists to build relationships with county and state extension faculty will provide an opportunity to convey its message through channels that already have established relationships with agricultural, forestry, and water resource managers. As any new technology, its initial adoption rate depends not only on meeting technical expectations, but also on trust between the message conveyor and potential users.

Strategy to interface with state weather network services: Collaboration between the SECC, the Florida automated weather network (FAWN), and the Georgia automated environmental monitoring network (GAEMN) has the potential to provide valuable benefits to all participants. The desire of each organization is to work toward seamless interconnectivity between the current activities undertaken by each. Operationally, the automated networks will continue to collect, process, and analyze real-time data and provide alerts and forecasts at the daily and weekly time scales. At the AgClimate web site, the SECC provides similar products as monthly to seasonal outlooks and over the three states region as well as for counties. The development of updated or hybrid forecasts based on recent real-time data and future forecasts will provide the most accurate and reliable source of information for stakeholders. The development of an automated process by which monthly and seasonal forecasts are updated with recent information and made available to clients of FAWN, GAEMN, and AgClimate is the first step. The SECC is examining mechanisms to pursue funding resources and collaborative agreements to achieve this level of integration.

Monitoring and Evaluation

The issues of monitoring and evaluation are closely related. Monitoring is essentially an internal activity, which measures progress toward project objectives to inform PIs and the program coordinator. Evaluation is an activity designed to measure the effectiveness and significance of project interventions. In effect, evaluation builds on data gathered during monitoring and program performance evaluation, and together they constitute on-going, continuous processes. A key feature of the SECC M&E effort is its participatory nature. Monitoring and evaluation will involve stakeholders not just as sources of information but as active participants in the process. We will engage agricultural producers, natural resource

managers, government regulators, local communities, and other relevant stakeholders to collaborate in the processes of problem definition, identification of objectives, indicators and desired outcomes.

In the Climate Extension Program we will evaluate:

- Perceptions, attitudes, and potential uses or adaptations by agricultural producers of the forecast products.
- Perceptions, attitudes, and adoption by Extension agents of SECC climate forecast products.

Data will be collected for monitoring extension projects through internal reports, published papers, and technical reports. Specially designed surveys, interviews, direct measurement, and rapid rural appraisal techniques such as Sondeos will be used. Our monitoring program will be a combination of several methods including examination of administrative records, rapid rural appraisals, sample surveys, and in-depth interviews.

Table 2. Indicators, methods, and sources of data for SECC monitoring and evaluation

<i>Potential Indicators</i>	<i>Method</i>	<i>Source(s) of data</i>
Positive perception of forecast usefulness	Sondeos, interviews	Extension agents, producers, water managers
Adaptations to agricultural practices	Sondeos, Interviews	Producers, Extension agents
Usefulness of AgClimate website	On-line Survey	Producers, Extension agents, general users
Knowledge ex ante and ex post of ENSO effects in Florida, and potential adaptations	On-line Survey	Producers, Extension agents, general users
Access to forecasts by marginalized groups	Sondeos, interviews, focus groups	African American, Latino, Haitian, Female, Organic, lifestyle, and other small-scale producers
Usefulness to water managers	Interviews	Personnel from water management districts, producers, municipal water managers
Overall SECC institutional activities	Interviews and documentary review	Relevant institutional actors and SECC researchers.

Evaluation of the Climate Extension Program will identify reasons for success or failure of end user adoption of seasonal climate forecast products. Evaluation will have the primary role of drawing out critical lessons relevant for the future of the project or other projects of a similar nature. Evaluation will be used for operational purposes and as an analytical tool to improve project design.

- *Program Monitoring Evaluation*: In program monitoring evaluation, the fundamental question is: Is the program reaching the target group? And concurrently, is the program delivering the products, tools, and information it was designed to deliver? To determine if the target population has been reached examination of records, interviews with program participants and community surveys, where applicable, are useful methods. This type of evaluation will also help determine if products were delivered in a timely manner, were useful to the clients, and were delivered according to plan. There is in fact, no sense in determining impact if services or products were not delivered.
- *Program Performance Evaluation*: A measure of whether the program has been sufficiently well implemented so that there is no question that the critical services of goods have been delivered to the appropriate targets is necessary. This will be considered a measure of performance rather than impact. However, just as monitoring feeds into impact assessment, so should Program Performance Evaluation.
- *Program Impact Evaluation* will take place in order to report back to donor agencies and to guide the SECC research and development process. Impact assessment will allow for improved monitoring of project progress. Two levels of impact will be measured, i.e. impact on extension agents, and impact on producers. In order to effectively assess the impact of a program the projects goals must have been well articulated enough to make it possible to identify goals of achievement. As the SECC is continuously learning, evaluators in each state will establish what targets or thresholds to measure and what new ones should be addressed in collaboration with project participants and relevant stakeholders.

To recap monitoring and evaluation efforts – we will continue to devise and update methodologies for assessing seasonal climate forecasts products and their use. Our aim is to understand potential adoption by end users by eliciting their regular feedback through several sociological and anthropological methods. Information gleaned during participatory data collection will allow the SECC and its partners to expand or shift current work and to identify new potential uses and evolving user perceptions over time. The assessment framework will also facilitate evaluation of new products such as experimental forecasts; and use of our climate forecasts for improved management in agriculture, forestry and water resources.

Summary

An innovative climate extension program is being implemented in the southeast USA. Our vision is that agricultural, forestry, and water resource managers will better cope with uncertainty and climate associated risks through routine and effective use of climate forecasts and climate related decision support tools. An important component of the program is a partnership with State Cooperative Extension Services for the development and implementation of climate outreach and education programs.

APPENDIX A

CURRENT SECC EXTENSION ACTIVITIES

Category	Activities	AU	FSU	UF	UGA	UM	UAH
Outreach & Relationship Building	Visits to identify needs and obtain feedback	x	x	x	x	x	x
	Organize and deliver training activities (workshops, in-service training)	x		x	x		
	Participation in traditional extension outreach (field days, grower meetings)	x	x	x	x	x	
	Production on extension publications (UF EDIS and similar)	x	x	x	x	x	
	Presentations in conferences	x	x	x	x	x	x
	Peer reviewed publications	x	x	x	x	x	x
Research & Development	Development of new AgClimate (web-based) tools						
	1. Conceptualization	x	x	x	x	x	
	2. Programming		x	x	x		
	3. Interface design and programming		x	x	x		
4. Testing and transfer to AgClimate		x	x	x			
Research & Development	Development of information material for the AgClimate web site						
	1. Interaction with “experts”	x	x	x	x	x	
	2. HTML coding and implementation		x	x	x		
Research & Development	Proposal and conduction of research projects for development of new information	x	x	x	x	x	x
Maintenance Operations	Forecasts						
	1. ENSO phase forecasts (annual)		x				
	2. GCM-based forecasts		x				
	3. Freeze forecasts (annual)		x				
	4. Hurricane forecasts (annual)		x				
	5. Forest wildfire risk forecasts (monthly, Jan-Jul)		x				
	6. Crop yield (annual, in-season)			x	x		
Maintenance Operations	Update AgClimate information		x	x			
Maintenance Operations	Update and review AgClimate HTML codes and links		x	x			
Maintenance Operations	Update AgClimate databases						
	1. Climate database		x				
	2. Crop Model Results			x			
Maintenance Operations	3. Historical yield database			x			
Maintenance Operations	Maintain AgClimate web-based tools			x	x		
Monitoring & Evaluation	Program monitoring					x	